

SOLITAIRE

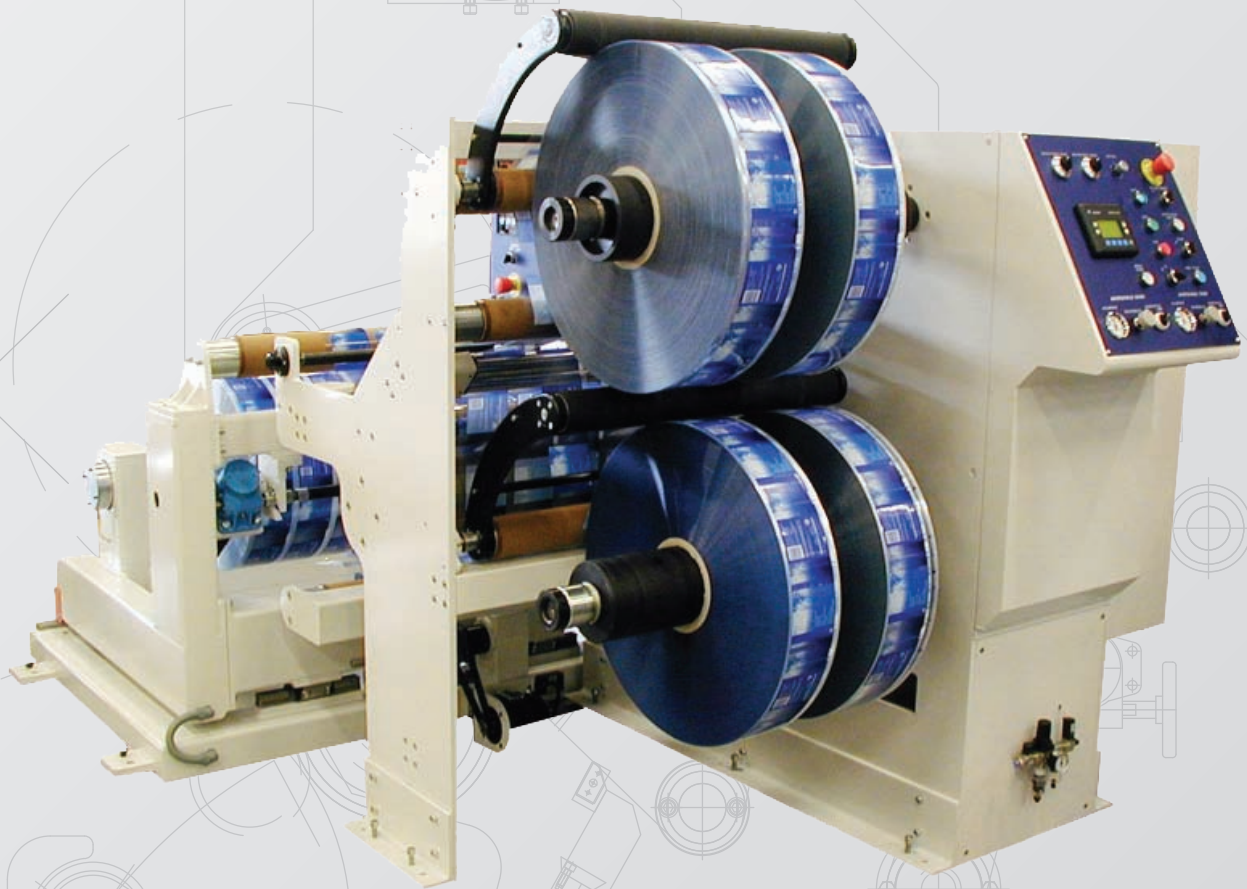

SOLITAIRE
SERIES

**Versatile Narrow Width
Slitter Rewinders**

The Solitaire is a proven Slitter that has been in production for 20 years. It is dedicated to unsupported film, slitting and rewinding at the highest speeds possible using a.c. drive technology that produces exceptional results.

Worldwide installations enable the Solitaire range to be a guaranteed market leader giving complete piece of mind to the narrow web and mid web Converter.

The machine can be configured to run multiple substrates including papers, laminates, films and even aluminium foil, with operating speeds of up to 500m/min (1640ft/min).

Finished slit reels that accommodate 20,000+ wrap-around labels, for example, typically a printed 40µ OPP product, can be wound in a time frame that cannot be equalled on any other known narrow web finishing machine.

SOLITAIRE



SOLITAIRE SERIES

VERSATILE FILMIC SLITTER REWINDERS

UNWIND

- ASHE edge Guider (Servo) with facility to track any printed line or edge.
- Electric reel lift - no hydraulics
- Braked Unwind with automatic diameter calculation.
- Closed loop tension option plus driven unwind if required.

SLITTING STATION

- Suitable for razor in air, razor in groove and driven rotary shear.
- Lift out female knife bar for ease of knife setting.
- Knife oscillation facility as standard, dedicated to improved blade life expectancy.

OTHER MACHINE FEATURES

- Vacuum drive roller for tension isolation - no nip assembly eliminating creasing.
- Maximum machine speed of 500m/min.
- Small machine footprint.
- All electrically driven machine using servo technology.
- Environmentally friendly.
- Complete integrated PLC touch screen with fault diagnostics.

REWIND

- Unique diameter computation - no diameter sensors or measuring devices.
- Ball locking type differential rewind shafts for 70mm, 76mm and 152mm cores.
- Airshafts also available for any other size of core.
- Adjustable layon roller control for high speed operation.
- 2 or 3 motor drive system, depending on products to be run.
- Cantilevered when unloading for ease of finish reel removal.
- Wide range of unloading devices (Standard mobile trolley shown).

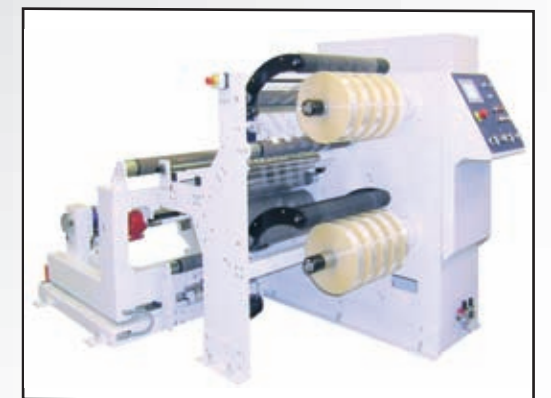
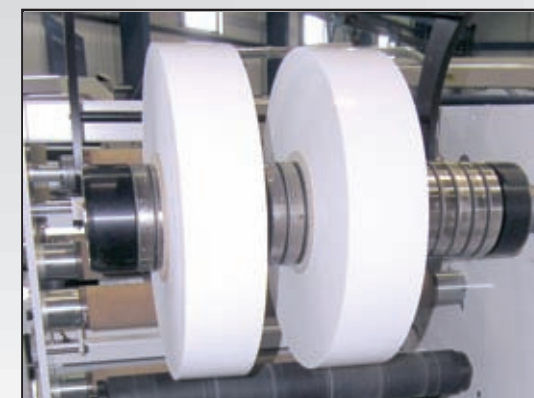
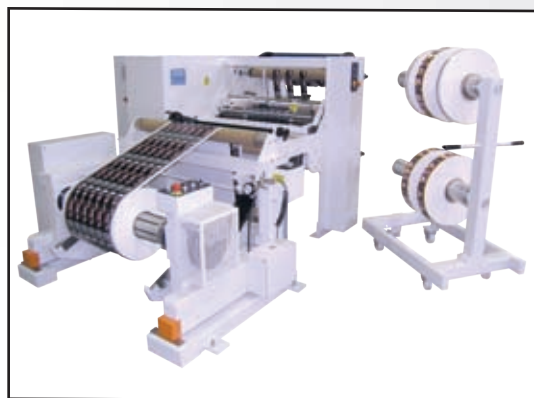

SOLITAIRE SERIES

VERSATILE FILMIC SLITTER REWINDERS

MACHINE SPECIFICATION

- ⦿ Any web width from 420mm to 800mm (16" to 32").
- ⦿ Shafted unwind with shaftless option.
- ⦿ Unwind diameters of 1000mm (40") or 1,270mm (50").
- ⦿ Rewind diameters of 600mm (24") or 800mm (32").
- ⦿ Maximum running speed 500m/min (1640ft/min).
- ⦿ Options available for inspection.
- ⦿ Servo web guide system for high speeds.
- ⦿ Offload systems to suit size of reels.

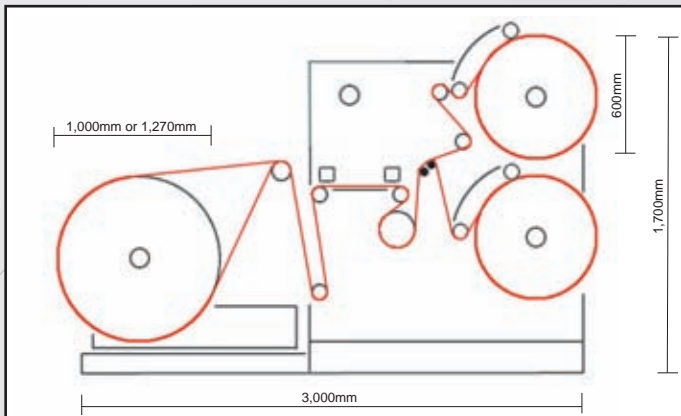

ASHE CONVERTING EQUIPMENT
St. Johns Works, Bluestem Road,
Ransomes Europark,
IPSWICH, IP3 9RR, United Kingdom
Tel: +44 (0) 1473 710912
Fax: +44 (0) 1473 719137
www.ashe.co.uk sales@ashe.co.uk

Also at:
Mr Guy Carrington
ASHE America Inc.
23 Marlboro Road, Brattleboro,
VERMONT 05301 U.S.A.
Tel: 802 254 0200 Fax: 802 254 1100
gcarrington@asheusa.com



Other Ashe Products



Jade Slitter Rewinder with
Individual Arm Winding



Sapphire S2 Slitter Rewinder



Diamond Duplex Slitter Rewinder



Onyx Duplex Slitter Rewinder